

OPERATION AND MAINTENANCE

MODEL 1085 HIGH FLOW SEQUENCE / PRIORITY VALVE

The model 1085 valve is an open-shut valve having two control pressure ports. When pressure is applied to the top port the valve opens. When pressure is applied to the side control port the valve closes. When no pressure or equal pressures up to 6000 PSI are applied to both control ports the valve is held open by a bias spring. The standard valve has about 250 PSI open bias however other springs can be provided for 0 to 400 PSI bias.

Its primary function is control of cascade systems used for such purposes as filling breathing air cylinders and vehicle CNG (compressed natural gas) tanks. Used between a compressor and cascade system of storage tanks the 1085 valve can be used to fill the highest pressure bank first, then the next highest etc without operator assistance. Here the 1085 valve permits the compressor to operate at the pressure of the bank being filled rather than the maximum system pressure as is the case with simple priority or back pressure valves. When used between the storage banks and tank being filled the 1085 valve can deliver gas from the lowest pressure bank until equalized, then the next higher pressure bank etc without operator assistance. The factory can be consulted for application details. A one inch thread section is provided on the end permitting a way to mount the valve. A one inch hole is required in a mounting plate or panel.

TECHNICAL SPECIFICATIONS

Maximum pressure, inlet	6000 PSI
differential	6000 PSI
outlet	6000 PSI
open or shut control	6000 PSI
Ports, inlet	1/4" MNPT
outlet	1/4" FMPT
open control	1/4" MNPT
shut control	1/4" FNPT
Flow coefficient (Cv)	0.8 (.23" orifice)
Materials, body	anodized aluminum
internals	brass & stainless
seals	Viton(TM) & KEL-F
Open bias - constant (from spring)	250 PSI 0 to 400 available
Open bias - pressure (This is % greater pressure required on shut control than open control to actuate valve)	7%

AQUA ENVIRONMENT INC.

INSTALLATION

Use a suitable pipe thread sealant such as teflon tape on inlet and outlet threads. Avoid over torquing pipe thread. Normal torque applied with a 6 or 8 inch long wrench is ample. Use ample teflon tape - 3 or 4 turns, not 1 or 2 turns. The inlet is the male thread at the bottom of the valve and the outlet is the lower female thread at the side of the valve. The control pressure port to close the valve is the upper side port and control pressure to open the valve is applied at the top male port. The one inch thread at the bottom of the valve can be used to mount the valve through a one inch hole in a panel or mounting plate provided by the user. Actuating or control pressure can be any non-corrosive gas or liquid at any pressure up to 6000 PSI. The regulator is NOT shipped oxygen clean and should NOT be used for oxygen service as provided. Consult the factory for details regarding oxygen service.

MAINTENANCE & REPAIR

CAUTION As with any regulator or valve, particulates or moisture can plug or freeze the internal filter or valve seat. This can occur when up-stream dryers are not changed or remain unused for long periods allowing corrosion materials to accumulate. In critical applications where it is important not to lose flow, a larger particulate filter should be used upstream. Also an orifice such as the Aqua model 796 should be used downstream. This reduces the tendency to freeze when moisture is present. Consult factory for details. The user should establish time intervals for changing the valve cartridge, filter and upstream dryers based on experience and service conditions. No representation is made herein concerning such time intervals as each use is unique. Back-up systems should be used in very critical applications since field maintenance is hard to insure. The poppet cartridge 895 is a factory assembled item and should be replaced if required and not disassembled unless absolutely necessary. Spare cartridges are available at a nominal cost and should be kept on hand if rapid repairs are required. Under severe conditions repacking of seals items 13, 14, and 15 with Cristo lub per the drawing may periodically be required. IN ALL CASES THE UNIT CAN BE RETURNED TO THE FACTORY OR DEALER FOR REPAIR UNDER WARRANTY IF APPLICABLE OR AT A NOMINAL CHARGE. Maintenance or repairs should only be done by qualified personnel in a clean environment by following the drawings and parts lists herein.

MODEL 1085 HIGH FLOW SEQUENCE VALVE ASSEMBLY & DISASSEMBLY

PARTS LIST

ITEM	QTY	PART NO.	DESCRIPTION
1	1	895	poppet cartridge assy
2	1	1070	body
3	1	1071	cap
4	1	815	stem
5	1	852	toggle cap
6	1	1022	nut
7	1	1019	upper body
8	1	1021	piston, control
9	1	509	spring guide (note 2)
10	1	1020	cap, control
11	1	1100-11	spring - HD (note 2)
	1	1100-11a	spring - MD
12	1	1100-12	2-017 viton, 90 duro seal
13	1	1100-13	2-015 viton, 90 duro seal
14	1	1100-14	2-008 viton, 90 duro seal
15	1	1100-15	2-006 viton, 90 duro seal
16		delete	
17	1	1100-17	2-020 viton, 90 duro seal
18	1	1100-18	2-028 viton, 90 duro seal
19	1	1100-19	1" x 14 jam nut, plt stl
20		1085-20	repair kit includes items 1,4,8,12,13,14,15,17,18

NOTES

- Use Dow 111 grease on O rings items 12, 17, & 18 and threads. Fully pack Cristo lub MCG 121 or MCG 111 or equivalent around O rings items 13, 14, & 15
- Spring bias options are as follow:
 spring - HD, no item 9 - 250 PSI bias (standard)
 spring - HD, with item 9 - 400 PSI bias
 spring - MD, with item 9 - 120 PSI bias
- Adjust item 6, nut so item 5 is just loose enough to rotate easily, then add two drops of locktite, red to thread between item 6 and 7
- Tighten nut item 5 on lower body item 3 after orienting the "close control" and "outlet" ports as desired.
- Technical bulletin - 1025
- Install O ring item 14 in body 7. Using drill shank or special tool position O ring as shown in body before inserting piston item 8. This prevents damage to O ring during installation.
- Knife cut small groove radially across item 7, upper body where it contacts item 3, lower body. This prevents an unwanted seal at this point.
- Drawing 896, "poppet cartridge" is part of this drawing.

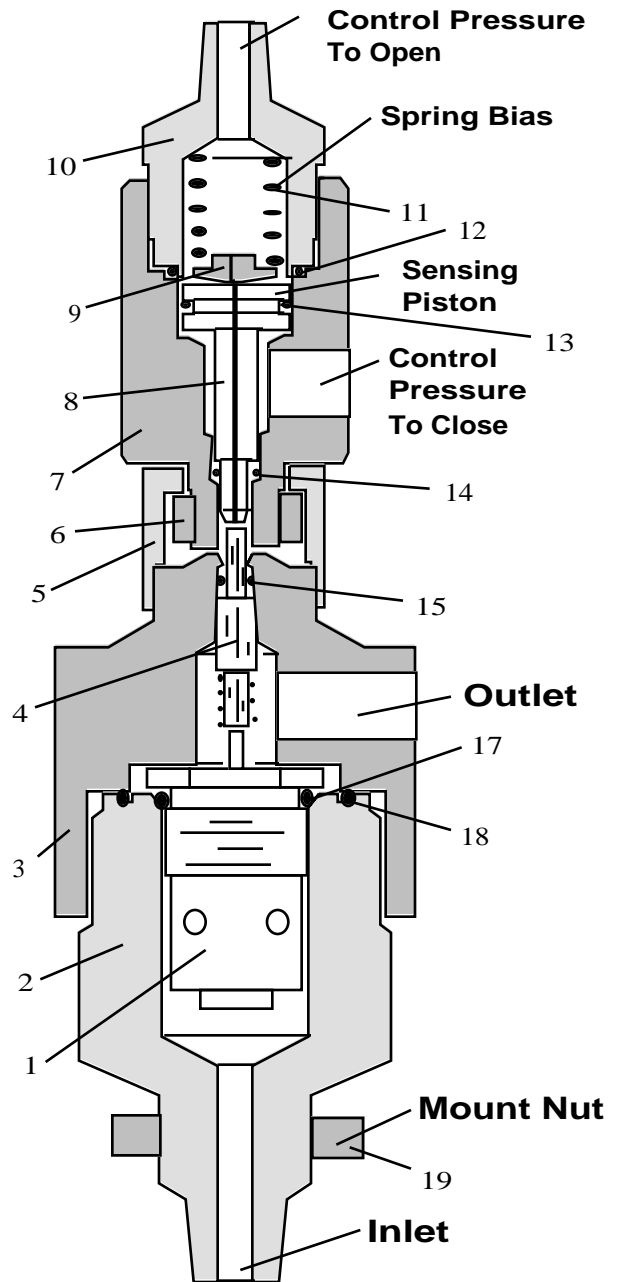

**Model 1085
Sequence Valve**