

OPERATION AND MAINTENANCE

MODEL 1247 REGULATOR

The model 1247 is a small, economical piston type spring loading regulator. It is suitable for either gas or liquid service. The regulator is self venting. Venting occurs when outlet pressure rises 20 to 60% above set pressure.

SPECIFICATIONS

- Maximum inlet pressure 6000 PSI (40 MPa)
- Outlet pressure 200 -1000 PSI (-1)
100-300 PSI (-2)
40-120 PSI (-3)
50-100 PSI (-4)
10-100 PSI (-5)
- Flow coefficient (C_v) 0.03
(equivalent to 0.040" orifice)
- Rise of outlet pressure with rise of inlet pressure 8 PSI/1000 PSI
- Materials - body and cap - aluminum
internals - brass, alum
seals - delrin, Buna N Viton
- Fittings 1/4" FNPT inlet
1/4"FNPToutlet
- Size 1.0" hex x 3.5" lg

INSTALLATION

The regulator can be mounted in line in a tubing or pipe run. Use a suitable pipe thread sealant such as teflon tape on the 1/4" inlet and 1/4" outlet connections. The 1/4" thread at the bottom (in item 1) is the inlet. Connect the inlet to the source gas such as a high pressure storage tank. The outlet is capable of being adjusted from 0 to 1000 PSI or lower pressure ranges depending on the spring used. (See drawing notes) AN OUTLET GAUGE AND RELIEF VALVE SET SLIGHTLY HIGHER THAN THE DESIRED OUTLET PRESSURE SHOULD BE CONNECTED TO THE OUTLET. IF THE INLET PRESSURE CAN EXCEED 6000 PSI A RELIEF VALVE SHOULD ALSO BE INSTALLED AT THE INLET TO PREVENT EXCEEDING 6000 PSI. Avoid overtorquing pipe threads. Normal torque with a 6 or 8 inch wrench is ample. Use ample teflon tape - 3 or 4 turns, not 1 or 2.. The regulator is NOT shipped oxygen clean and should NOT be used for oxygen service as provided. Consult the factory for details.

OPERATION

Outlet pressure can be adjusted by turning the body item 1 into or out of the cap item 3. Once desired pressure is obtained lock nut item 2 can be tightened against the cap 3 to prevent further movement. The regulator should not be set under pressure. It is intended primarily for applications where one outlet pressure is used.

MAINTENANCE & REPAIR

CAUTION As with any regulator or valve, particulates or moisture can plug or freeze the internal filter or valve seat. This can occur when upstream dryers are not changed or remain unused for long periods allowing corrosion materials to accumulate. In critical applications where it is important not to lose flow, a larger particulate filter should be used upstream. Also an orifice such as the Aqua model 796 should be used downstream. This reduces the tendency to freeze when moisture is present. Consult factory for details. The user should establish time intervals for changing the valve cartridge, filter and upstream dryers based on experience and service conditions. No representation is made herein as to time intervals as each use is unique. Back-up systems should be used in very critical applications since field maintenance is hard to insure. IN ALL CASES THE UNIT CAN BE RETURNED TO THE FACTORY OR DEALER FOR REPAIR UNDER WARRANTY IF APPLICABLE OR AT A NOMINAL CHARGE. Maintenance or repairs should only be done by qualified personnel in a clean environment by following the drawings and parts lists herein.

ASSEMBLY & DISASSEMBLY - MODEL 1247 REGULATOR

ITEM	QTY	PART NO.	DESCRIPTION
1	1	1251	body
2	1	1252	lock nut
3	1	1253	cap
4	1	1254	retaining nut
5	1	1255	seat
6	1	1256	poppet
7	1	1257	guide
8	1	1279	piston
9	1	1280	relief plate
10		delete	
11		delete	
12	1	1247-12	2-113 70N
13	1	1247-13-1	spring - 300-1000 PSI
		1247-13-2	spring - 100-300 PSI note 3
		1247-13-3	spring 40-120 PSI note 3
		1247-13-4	spring 50-100 PSI note 3
		1247-13-5	spring 10-100 PSI note 3
14	2	1247-14	seal 2-017 90V
15	1	1247-15	seal 2-012 70N
16	1	1247-16	seal 2-009 90V
17	1	1247-17	seal 2-009 90V
18	1	1247-18	filter
19		1247-19	REPAIR KIT - includes items 5,6,7,12,14 (2 ea),15,16,17,18

NOTES

1. Technical bulletin - 1250. test - 1249
2. Use Dow silicone grease 111 or equivalent on seals and threads. Except on seals 12 and 15 use Cristolub 121 or equivalent
3. Maximum allowable inlet pressure is limited at lower outlet pressures as follows:

OUTLET PRESSURE	MAX. INLET PRESSURE
150 PSI and up	6000 PSI
75 PSI and up	3000 PSI
40 PSI and up	1500 PSI
20 PSI and up	600 PSI

4. ASSEMBLY

- a. Clean all part and insure there are no visible chips or particulates.
- b. Inspect seat 6 under 10X magnification at sealing edge.
- c. Assemble parts as shown on drawing

5. Outlet pressure ranges are:

11247-1	200-1000 PSI
1247-2	100-300 PSI
1247-3	40-120 PSI
1247-4	50-100 PSI
1247-5	10-100 PSI

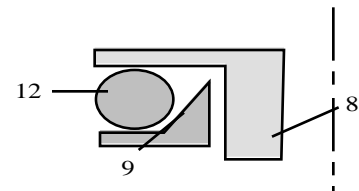
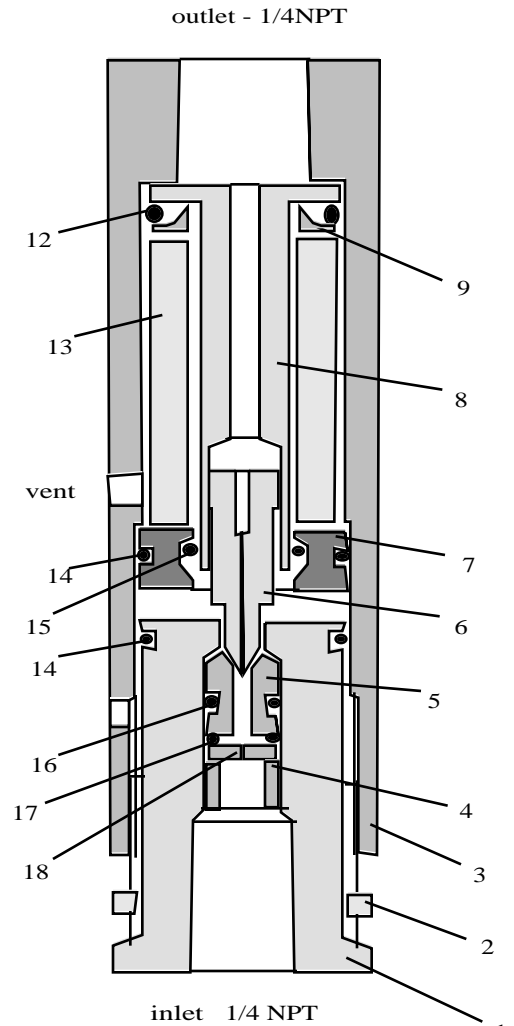

Relief installation detail