

OPERATION AND MAINTENANCE

MODEL 504 & 504H RELIEF VALVE

The model 504 is an economical, small, high pressure relief valve having excellent set pressure control over a large pressure range to 6000 PSI. (6500 PSI for the 504H model) It stays bubble tight to within a few PSI of set pressure and reseats bubble tight even after many vent cycles. Safety wire holes are provided for optional locking of set pressure adjustment.

The relief can be either set prior to installing in the system or after. Set the relief above set pressure using the adjusting screw (item 6 in the drawing). Bring system pressure up to desired relief valve pressure then back off the adjusting screw until the relief valve vents. Use the locking nut (item 7) to lock the position of the set screw. Cycle pressure once or twice to insure the relief opens at the desired pressure. Safety wire holes are provided in the body and adjusting screw. The regulator is NOT shipped oxygen clean and should NOT be used for oxygen service as provided. Consult the factory for details on oxygen service.

SPECIFICATIONS

- Set pressure ----- adj. 300 to 6000 PSI (6500 PSI for 504H)
- Leakage ----- bubble tight
- Max. flow (air) ----- 100 SCFM at 3000 PSI
50 SCFM at 1500 PSI
- Equivalent orifice ----- .078 inch dia.
- Fluids ----- gas or liquid
- Inlet ----- 1/4" male NPT
- Outlet ----- side vent
- Size ----- 7/8" hex by 2.1" long
- Temperatures ----- -40F to 160F
- Materials ----- bronze, anodized aluminum, & Viton

MAINTENANCE & REPAIR

Routine maintenance is generally not required. As mentioned above, the relief is sensitive to solid particles flowing through it. As with any relief valve, these particulates tend to lodge on the sealing surfaces or damage the sealing surfaces as they pass through. The result is leakage after the valve reseats.

In the event of leakage, the valve can be repaired as follows. (Refer to the drawing on the opposite side of this sheet.) Remove adjusting screw 6, spring 8, spring guide 5, and poppet 4. Inspect the sealing edge of the poppet 4 for scratches and seal surface 9 for imbedded particles. A 5X or 10X magnifier is helpful for this inspection. In most cases the problem will be imbedded particles in the seal. These can be removed with a Q tip, or tooth pick. If this does not correct the problem the seal 9 and possibly the poppet 4 will need to be replaced. To replace the seal 9, remove poppet guide 3 using a large screwdriver. If a new seal is not available the old seal can be turned over and reinstalled. This exposes a fresh sealing surface. The seal is a 90 durometer (extra hard) size 2-006 O ring. These are readily available. When installing the seal insure washer 6 is installed under the seal as shown. Insure the seal and washer stay in place until the guide 4 is installed. Torque guide 4 about as tight as possible while holding the relief valve body - i.e. without using a wrench on the body.

IN ALL CASES THE UNIT CAN BE RETURNED TO THE FACTORY OR DEALER FOR REPAIR UNDER WARRANTY IF APPLICABLE OR AT A NOMINAL CHARGE. Maintenance or repairs should only be done by qualified personnel in a clean environment by following the drawings and parts lists herein.

INSTALLATION

Use pipe thread sealant Teflon tape on inlet and outlet threads. Avoid over torquing pipe thread. Normal torque applied with a 6 or 8 inch long wrench is ample. Use ample Teflon tape - 3 or 4 turns, not 1 or 2 turns. It is important to maintain piping internals free of particulates such as metal chips, dirt, weld slag, etc. If present these will tend to lodge in the relief valve when it opens causing damage to the seat and leakage. Since it is difficult to keep piping completely clean during assembly it is advisable to blow high velocity air through the system and out the relief valve port just prior to installing it. This can normally clean the system of particulates. A high pressure air tank can provide a strong flow for this cleaning operation. Suitable ear and eye protection should be used when flowing high pressure air. It is NOT advisable to install any type of filter before the relief valve. A filter could become clogged disabling the safety function of the relief.

MODEL 504 & 504H RELIEF VALVE ASSEMBLY & DISASSEMBLY

PARTS LIST

ITEM	QTY	PART NO.	DESCRIPTION
1	1	505	body
2	1	506-1	washer
3	1	507	guide
4	1	508-1	poppet
5	1	509-1	spring guide
6	1	510	pressure adj. screw
7	1	511	lock nut
8	1	504-8	spring (6000 PSI max)
	1	504-8H	spring for 504H (6500 PSI)
9	1	504-9	seat - 2-006 - 90duroViton
10	1	504-10	label

NOTES

1. Adjust using 5/16" Allen wrench
2. Inlet is 1/4" MNPT
3. Technical bulletin is 651
4. Repair kit - part number 504-12 includes items 4 and 9

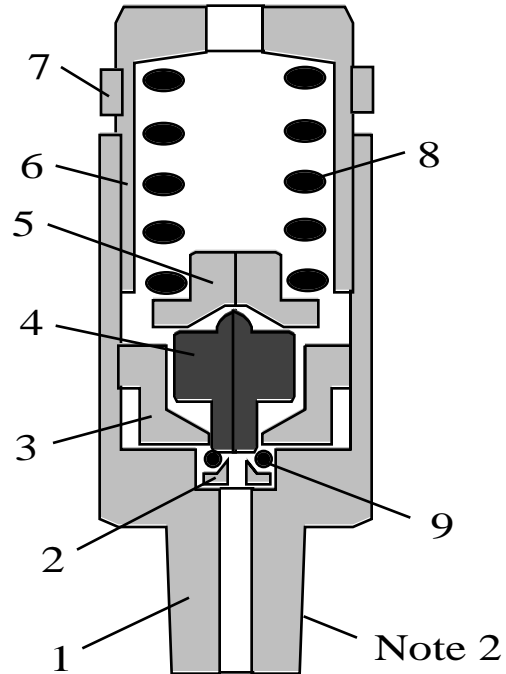

AQUA ENVIRONMENT INC.