

OPERATION AND MAINTENANCE

MODEL 635 BACK PRESSURE REGULATOR

GENERAL

Also known as a priority valve, the model 635 is a fully balanced economical regulator. It is similar to our model 211 regulator but is capable of much higher flows. It is used primarily on compressors to maintain back pressure on filters and separators thus improving their efficiency as much as 1000 %. The stainless steel metal to metal seat is designed to be self cleaning and prevent freeze up. It maintains constant back pressure (set pressure) independent of outlet pressure. When outlet pressure (such as in a tank being filled) reaches set pressure the regulator opens fully permitting unrestricted flow. Normally the valve is set for back pressures of 1500 to 6000 PSI. However, it can be operated with set pressures as low as 150 PSI. Lighter than standard springs can be ordered to improve low pressure operation.

SPECIFICATIONS

- Maximum rated pressure - 6000 PSI (40 MPa)
- Set pressure -1800 PSI nominal (adj. 150 to 6000)
- Materials - anodized aluminum body, bronze, stainless
- Flow capacity - 2 to 300 SCFM
- Leakage - zero external; 0.1 SCFM internal
- Ports - 1/2" female pipe thread
- Size - 5.3" x 2" x 1.5"

INSTALLATION

Use a suitable pipe thread sealant such as teflon tape on the inlet and outlet ports. Connect the inlet to the source gas such as a compressor. If the regulator is installed in a piping line insure it is adequately supported or adjacent piping is supported so any possible force on the regulator or piping will not damage or break it. The 1 1/4" by 12 pitch thread on the spring housing at the top of the regulator can also be used for mounting. A 1 1/4" hole in a mounting plate or panel will support the regulator using either a standard jam nut or p/n 952 mounting nut. (The 952 nut is smaller than a standard nut.) The regulator is NOT shipped oxygen clean and should NOT be used for oxygen service as provided. Consult the factory for details on oxygen service.

OPERATION

In operation the back pressure regulator will maintain it's set pressure upstream and allow just enough gas flow to hold this pressure. The set pressure can be adjusted by loosening the 3/8" jam nut and turning the adjusting screw. Set pressure is pressure at the inlet port when gas is flowing through the regulator.

MAINTANENCE & REPAIR

Routine maintenance is generally not required. Under extended or severe operation it is helpful to relubricate the poppet seal item 10. (see drawing on opposite side). To disassemble, back off adjusting screw item 8 to relieve pressure on the poppet. Seat 2 can then be removed using a large screwdriver. Remove cap 4 then poppet 3 can be pushed out of body 1. Position seal 10 on poppet 3 about 1/8 inch from shoulder on the poppet. Fully pack the area between the shoulder and the seal with Cristo-lub MCG 121 grease or equivalent. Also apply a heavy coat of grease on the remaining area of the poppet stem. Drop poppet 3 back into body 1. Lightly grease the threads and seal 11 on seat 2 and screw tightly into the body. Reinstall spring, spring guides and cap as shown. Reset regulator by applying pressure to the inlet and adjusting set screw 8 so flow starts at the desired set pressure. Accessive leakage can occur internally between the inlet and outlet resulting in a drop of set pressure. This is generally due to dirt or other particulates damaging the seat 2. Leakage can sometimes be reduced by tapping ball 7 against seat 2 thus forming a new seal surface. This can be done by removing cap 4 and tapping on poppet 3 with a small hammer. If this does not work seat 2 must be replaced. A repair kit (p/n 635-14) is available. **IN ALL CASES THE UNIT CAN BE RETURNED TO THE FACTORY OR DEALER FOR REPAIR AT A NOMINAL CHARGE.**

ASSEMBLY AND DISASSEMBLY

Assembly and disassembly can be done by following the drawing and parts list below. Also refer to the repair section for disassembly sequence.

7. torque seat item 2 to 0 to 1 inlb ((higher torque increases leakage) - optionally lightly tap poppet item 3 before installing spring housing to help form seat.

PARTS LIST - 635 BACK PRESSURE REGULATOR

ITEM	QTY	PART NO.	DESCRIPTION
1	1	636	body
2	1	639	seat
3	1	640	poppet
4	1	903	cap
5	1	410	spring guide
6	1	379-5	spring
7	1	644-1	ball
8	1	644-2	adjusting screw (3/8"NF x 1.25 lg)
9	1	644-3	lock nut
10	1	644-4	seal (2-011, Viton duro75)
10a		644-4a	seal (2-011, N756-75) see note 5
10b		644-4b	seal (2-011, L1120-70 or M25988/1-011 Fluoro silicone - note 5
11	1	644-5	seal (2-015, 90 duro V)
12	1	644-6	label
13	1	849	spring guide, lower
14		635-14	repair kit - includes item 2,3,7,10,11
15	1or2	952	mount nut - optional
16	1	644-16	back up ring - TFE spiral MS28782-6 see note 5

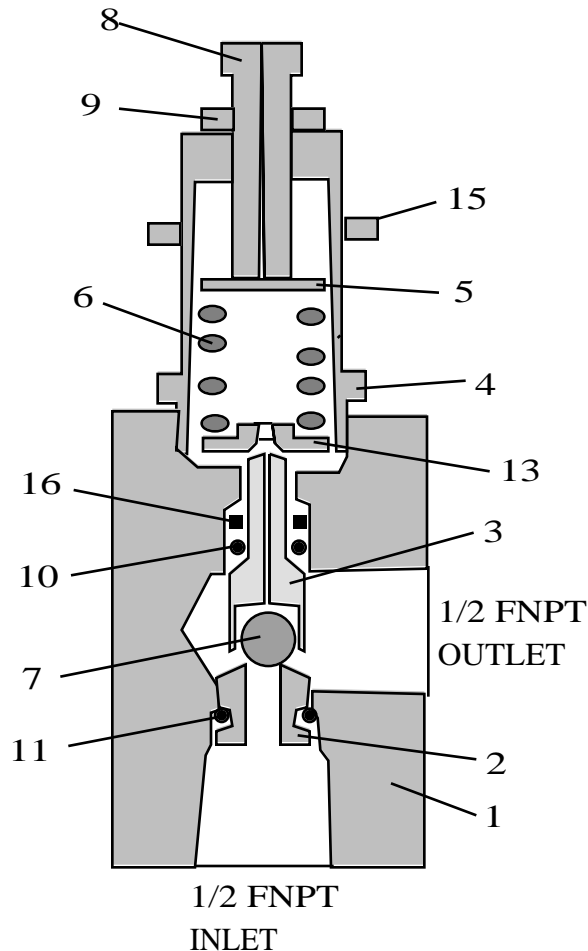

NOTES

1. Inlet and outlet fittings are 1/2" female NPT
2. Fully pack area between items 3 and 10 with TFE filled Perfluoroalkylether grease per MIL-G-27617 types 2 and 3 such as Cristo-lub MCG 111 or 121, Krytox or Tribolube-16
3. Use a light coat of Dow 111 grease on items 2 and 11.
4. Nominal set pressure is 1800 to 2000 PSI.
5. For lower temperature seal requirements use item 10a or 10b and 16 as shown instead of item 10 alone. Part number designation is below.

PART #	MIN TEMP	SEALS USED
635	+10F	10 & 16
635L	-50F	10a & 16
635EL	-80F	10b & 16

6. **CAUTION** - WHEN USED WITH CNG OR CRYOGENS WARM TO ROOM TEMPERATURE BEFORE DISASSEMBLY - TRAPPED GAS BEHIND BALL SEAL CAN EJECT IT WITH FORCE AS IT WARMS.